

# PF1 Series

Filter M5

Air preparation  
unit

PF1 Series



Symbol



## How to Order

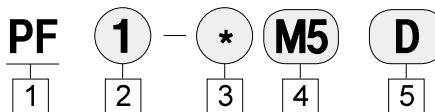

1 Series(Filter Unit)

2 Body Size  
1 : 1/8

3 Screw  
Blank : Rc  
N : NPT  
G : G(PF)

4 Port Size  
M5 : M5

5 Drain Option  
Blank : Manual Push Drain  
D : Auto Drain (N.O Type)  
Note1) Differential pressure type  
Auto Drain

## Specifications

Fluid	Pressed Air
Max.operating pressure(MPa)	10bar (1,0MPa)
Proof pressure(MPa)	15bar (1,5MPa)
Ambient and fluid temperature (°C)	-5~60(With no freezing)
Filtration rating(μm)	10μm (Option : 2, 5, 20, 40)
Bowl material	Polycarbonate (Option : ALDC)

## Structure

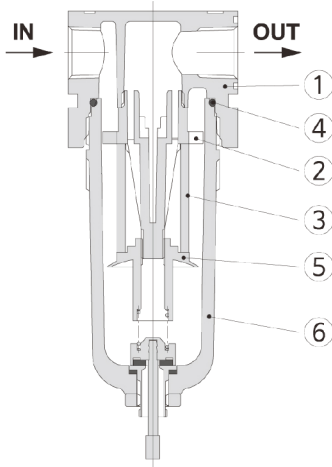

### Major Parts LIST

#	Part Name	Material
①	Body	Iron die casting
②	Impera	ABS
⑤	Baffle	ABS
⑥	Bowl Ass'y	PC

### Spare Parts LIST

#	Part Name	Material	Part Number
			PF1
③	Element	Foam resin	F100-EL
④	O-ring	NBR	S22

## Dimensions

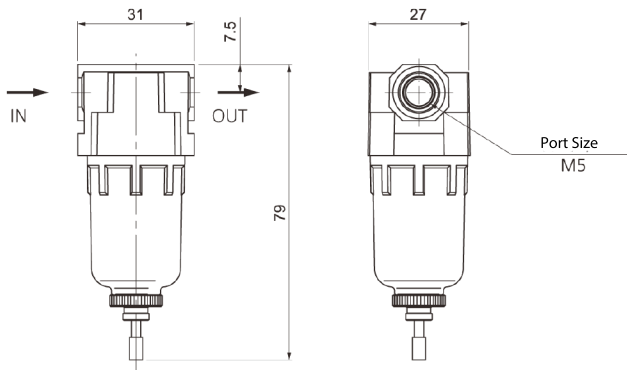

## Flow Characteristics

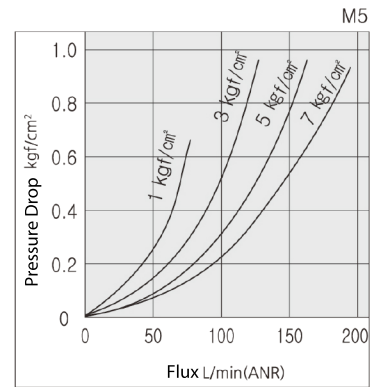

## Dimensions when options are attached

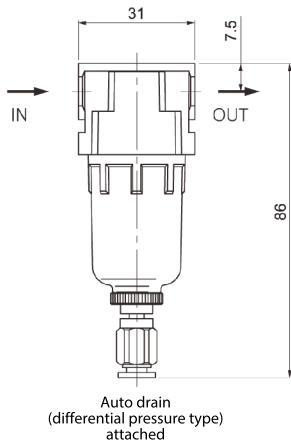

Option	D : Auto drain (differential pressure type)
Product Name	<p>Φ4mm One-touch fitting</p>