

Series **PL5**

Lubricator 3/4" and 1"



Standard Specifications

Fluid	Air	
Max. Operating Pressure (MPa)	1.0(140psi)	
Proof Pressure (MPa)	1.5(200psi)	
Min Operating Flow (N ℓ /min)	150(5.3scfm) (1 ~)	
Bowl Capacity (cm ³)	109(3.69oz)	
Ambient and Fluid Temperature (°C)	-5~60(23~140°F) (Non-freezing)	
Flow Capacity ※	3/4 ~	9,400(332scfm)
(N ℓ /min)	1 ~	9,900(350scfm)
Bowl Material	Polycarbonate	
Bowl Guard Material	Nylon	
Recommended Oil	ISO VG32(Turbine Oil 1 Class)	
Weight(kg)	1.08(2.38lb)	

※ Test conditions : Supply pressure 0.6MPa(90psi), pressure drop 0.05MPa(7psi)

Symbol

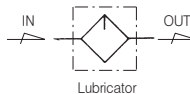

How to Order

PL 5 — * 10 B — *

Series (Lubricator Unit) — **PL 5**

Thread — **10**

Blank	Rc(PT)
N	NPT
G	G(PF)

Port Size — **B**

06	3/4
10	1

Other Option

R	Flow direction : Right-Left
XC16	Copper-free

Bracket Option

Blank	None
B	Bracket

Note1)

Note2) Separately packed, Not assembled.

Series PL5

Construction

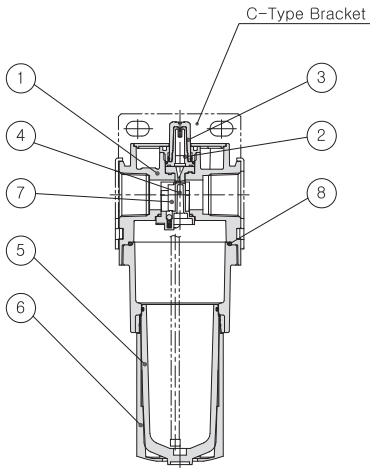

Main Parts/Parts List

NO.	Description	Material	Remark
①	Body	Aluminum	
②	Inner Sight dome	Nylon(Transparent)	
③	Outer Sight dome	Nylon(Transparent)	
④	Damper Plate	Acetal	
⑤	Bowl	Polycarbonate	
⑥	Bowl Guard	Nylon	

Replacement Parts/Parts List

NO.	Description	Material	Part No.
⑦	Damper	NBR	PL5-34-001-01
⑧	Bowl O-ring	NBR	TAF4000-08-6000

Dimensions

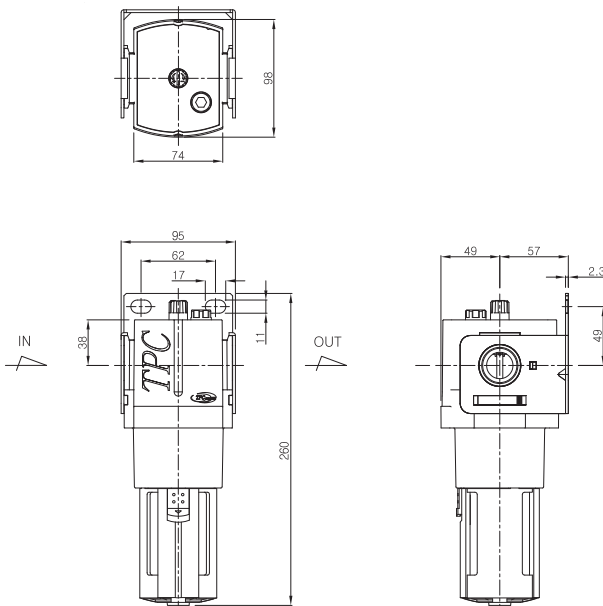

Flow Characteristics

▶ 3/4" PL5

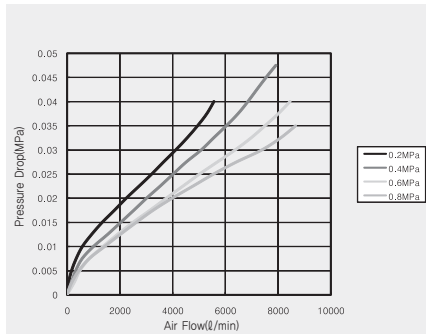

▶ 1" PL5

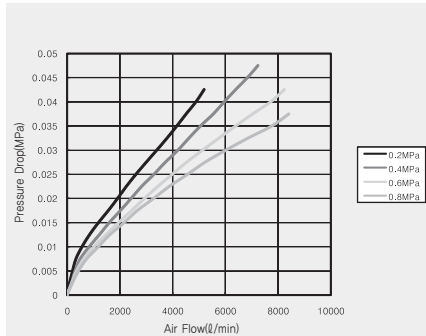

PC2

PF2

PR2

PL2

PP2

PC3

PF3

PR3

PL3

PP3

PC4

PF4

PR4

PL4

PP4

PC5

PF5

PR5

PL5

PP5

PFH(U)2~
PFH(U)5

PPH(U)3~
PPH(U)4

PLV

PSH

PCV

MB