

# PP1 Series

## Piggyback M5



PP1

### Specifications

Fluid	Pressed air
Max. operating pressure (MPa)	10 bar (1.0MPa)
Proof pressure (MPa)	15 bar (1.5MPa)
Ambient and fluid temperature (°C)	-5 ~ 60 (anti-freezing)
Filtration	10 $\mu$ m (option : 2, 5, 20, 40)
Bowl material	Polycarbonate (option : ALDC)
Structure	Relief type

### Symbol

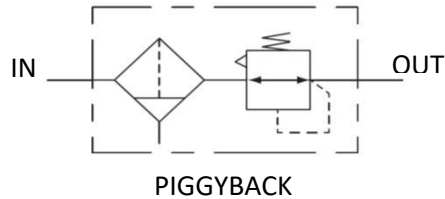

### How to order

**PP 1 - \* M5 BDP**

Series (Piggyback Unit) | Size

1	1/8
---	-----

Options

Blank	No bracket / manual drain / gauge
B	Bracket
D	Auto drain
P	Pressure gauge

Port size

M5	M5
----	----

Thread type

Blank	Rc
N	NPT
G	G(PF)

# PP1 Series

## Structure

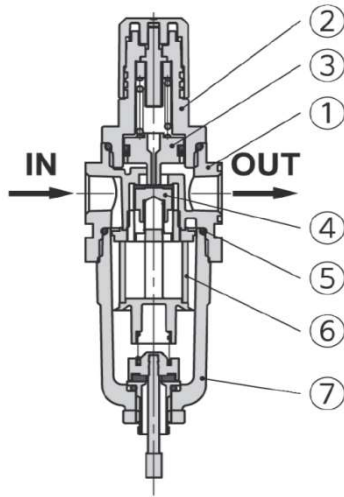

### Main Parts List

No.	Description	Material
①	Body	Zinc die casting
②	Cover	N66G
③	Piston	N66G
④	Check Ass'y	Brass, NBR
⑦	Bowl Ass'y	PC

### Supplementary Parts List

No.	Description	Material	Part no.
			PP1
⑤	Element	-	W100-EL
⑥	O-ring	NBR	S22

## Dimensions

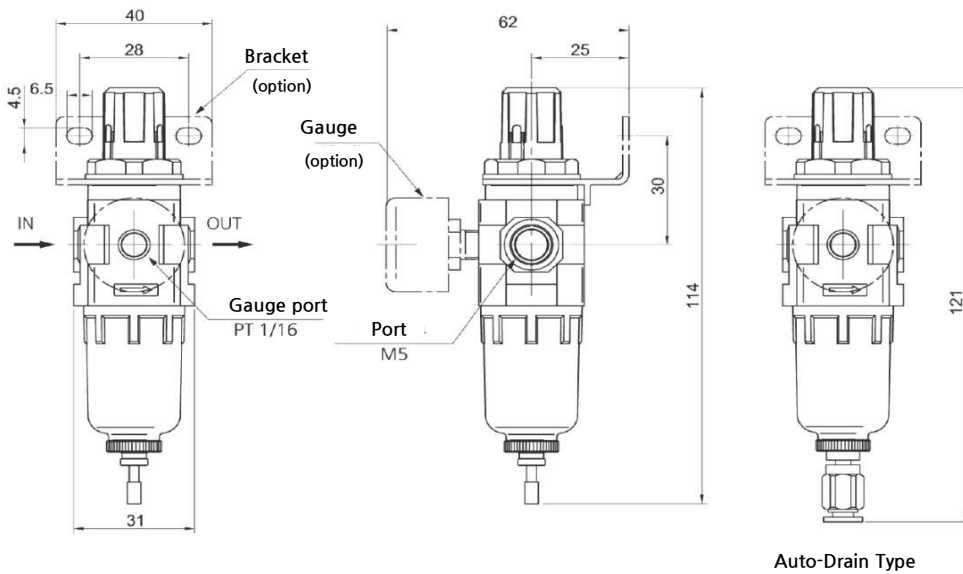

Auto-Drain Type

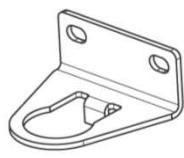
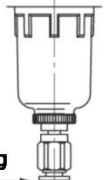
Option	P : Gauge	B : Bracket	D : Auto drain
Item	 G25, R1/16	 B120	 ø4 One-touch Fitting