

Series SP

Speed Controllers

SN
SP2000
SP4000
SQ
SC
SP
SHF·SHS
DC
SQ2
ST
SF

Speed Controllers



Features

- MINIMIZES INSTALLATION TIME AND COST
- BODY SWIVELS 360°
- SPEED CAN BE ACCURATELY CONTROLLED EVEN AT LOW SPEEDS
- CONSTANT SPEED IS EASILY SET

Symbol

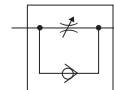

How to Order

SPM 1 2 0

1 2 3 4

1 Speed Controller
(Threaded Elbow Type)

2 Port Size
1 : R(c)1/8
2 : R(c)1/4
3 : R(c)3/8
4 : R(c)1/2

3 Type
2 : Direct connection type

4 Controlled Method
0 : Meter-Out
1 : Meter-In

Standard Specifications

Type		SPM12□	SPM22□	SPM32□	SPM42□
Port Size	Cylinder	R(c)1/8	R(c)1/4	R(c)3/8	R(c)1/2
	Tube	R(c)1/8	R(c)1/4	R(c)3/8	R(c)1/2
Proof Pressure		1.05MPa(149.3psi)			
Max. Operating Pressure		0.7MPa(99.5psi)			
Min. Operating Pressure		0.1MPa(14.2psi)			
Ambient and Fluid Temperature		5~60°C(41~140°F)			
Number of Needle Rotations		8 turns			
Weight(g)		36	74	141	238

SPM

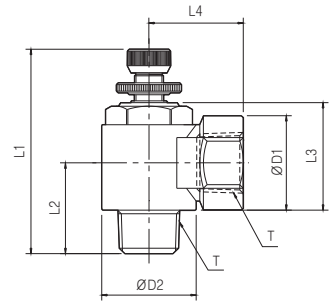

METRIC-BSPT(R)

Unit : mm

MODEL	T	L1	L2	L3	L4	D1	D2
SPM120	R(c)1/8	46.4	18.3	18.7	17	14	15
SPM220	R(c)1/4	49.4	23.1	23.2	22	20	20
SPM320	R(c)3/8	58.5	25	29.6	26	26	26
SPM420	R(c)1/2	63.9	27.7	28.3	38.5	27.5	28.3

※ SPM × ×0(Meter-Out) and SPM× ×1 (Meter-In) are same dimension.